



PROFIRE VM80 MANUAL^{REV 1.3}
MOTOR OPERATED ACTUATOR

The Profire VM80 is a motor-operated, control-valve actuator with responsive, accurate positioning, making the VM80 an ideal choice to operate any linear proportional control-valve.

1	Overview	2
1.1	Power Consumption.....	3
1.2	Specifications	4
1.3	VM80 Approvals	5
1.3.1	Hazardous Locations	5
1.3.2	Enclosure Ratings.....	5
1.3.3	Additional Standards.....	5
2	Installation.....	6
2.1	Safety Instructions	7
2.2	Unpacking	7
2.3	Actuator Mounting Instructions	8
2.4	Wiring Instructions.....	10
2.4.1	Standard Actuator Connection.....	10
2.4.2	Wiring Diagrams.....	10
2.5	Start-Up.....	13

3	Troubleshooting	14
3.1	Troubleshooting Guide	15
4	Maintenance	16
4.1	Replacing Seals	18
4.1.1	Stem Seal X-Rings	18
4.1.2	Cover O-Ring	19
4.2	Driver Replacement	20
4.3	Indicator Arm Replacement	21
5	Ordering Information	22
5.1	Service Locations	24

1 Overview

1.1 Power Consumption

The VM80 actuator operates on 12 or 24 VDC power and responds proportionally to a 4-20 mA control signal. DC power operation makes it ideal for use in low power applications typically found on remote sites.

Average power consumption in a typical process control application is less than 2.0 W based on a measurement of 1.85 W after a 5% movement every 25 seconds. **The resolution of the temperature control algorithm will ultimately determine the actual power consumption.** The higher the frequency of valve position changes, the higher the power consumption will be. Care should be taken to minimize valve position changes when possible on battery powered sites to prevent battery depletion.

DESCRIPTION	KIMRAY 1400® (1") SPECIFICATIONS	
	12 VDC	24 VDC
Supply Voltage		
Idle Power	1.1 W	1.2 W
Avg Power During Movement	5.6 W	21.3 W
Idle Current Draw	90 mA	49 mA
Average Current Draw	750 mA	886 mA
Max Current Draw	2.3 A	1.1 A

1.2 Specifications

DESCRIPTION	SPECIFICATION
Operating Temperature	-40°C to 55°C (-40°F to 131°F)
Duty Cycle	50 %
Control Signal	4-20 mA Current Loop
Operating Thrust	355 N (80 lbf) at 12 VDC, 387 N (87 lbf) at 24 VDC
Stroke Speed	2.54 mm/s (0.1 inch/s)
Travel (Nominal)	12.7 mm (0.5 inch)
Wiring Connection	30 to 14 AWG (see Table1 for recommended wire gauge)
Conduit Connections	One ½" NPT
Enclosure Material	Aluminum (Yoke: 6061-T6, Cover: A356-T6)

1.3 VM80 Approvals

The Profire VM80 is certified by CSA for the following hazardous location and enclosure ratings. (CSA Certificate No. 2014.2683637)

1.3.1 Hazardous Locations

AGENCY	REGION	PROTECTION STANDARD	MARKINGS
 C US	North America: Canada & USA	Explosion Proof: CSA C22.2 No. 30 UL 1203	Class I, Division 1, Groups B, C, & DT4
		Flame Proof: CSA 60079-1 ISA 60079-1	Class I, Zone 1, AEx d IIB+H2 T4 Gb
		General: CSA 60079-0 ISA 60079-0 FM 3600	

1.3.2 Enclosure Ratings

RATING	STANDARDS
Type 4X	CSA C22.2 No. 94.1 UL 50 MMX-J-235/1-ANCE CSA C22.2 No. 94.2 UL 50E MMX-J-235/2-ANCE NEMA 250
IP66	C22.2 No. 60529 IEC 60529

1.3.3 Additional Standards

ANSI/ISA 12.12.01

CSA Std C22.2 No. 0

CSA Std C22.2 No. 139

CSA Std C22.2 No. 142

CSA Std C22.2 No. 213

CSA Std. C22.2 No. 94

UL 916

UL Std No. 429

2 Installation

2.1 Safety Instructions

Failure to observe the following may result in death, personal injury, electrocution, property damage, product damage, and/or government fines.

1. Make sure the VM80 Actuator Cover (23) is threaded on completely and securely before applying power to the actuator in Hazardous Locations.
2. Installation of a conduit seal within 45.7 cm (18 inches) of the VM80 actuator and rigid metal conduit is required for explosion-proof applications.
3. Make sure circuits are not live prior to installation or while performing any maintenance.
4. Ensure designs used are approved by a qualified inspector and approved by the gas authority having jurisdiction at the site where the actuator is to be installed.
5. Use supply wire rated for a minimum of 120°C (248°F) or greater.

Consult your operations safety personnel for additional requirements.

2.2 Unpacking

Profire inspects and performs functional tests on all actuators prior to shipment. It is the responsibility of the customer to verify all products are undamaged upon receipt. Please carefully inspect the shipment for damage prior to installation.

1. Verify there is no visible damage to actuator, drive train, Actuator Stem (4), Stem Clamp (17, 18), and Plug Stem (29).
2. Check the Indicator Arm (15) for breakage
3. Make sure the Stem Clamp (17, 18) is secure if attached to a valve.

In the event of damage during shipment, the customer should take pictures of the damaged packaging and/or product, and immediately contact their Profire Sales Representative.

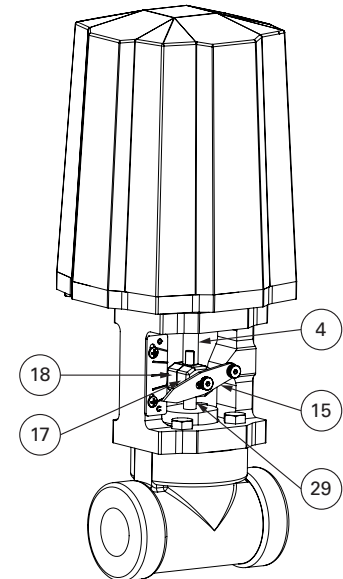

2.3 Actuator Mounting Instructions

NOTE: If you are installing a complete valve [actuator & valve body], proceed to section 2.4 Wiring Instructions.

1. Install the Actuator Assembly on the Valve Body Assembly so that the front of the Yoke (1) and the flow arrow on the Valve Body are facing you.

NOTE: This will be the normal flow of the valve. If the piping requires flow in the opposite direction, mount the actuator 180 degrees opposite to make sure the stroke indicator is visible to operators.

2. Make sure the Actuator Stem (4) and valve Plug Stem (29) are touching. If needed, raise the Plug Stem (29) using a flat-blade screw driver.
3. Place the Stem Clamp [Unthreaded – two holes] (18) on the back side of the stems making sure the grooves align.
4. Place the Stem Clamp [Threaded – three holes] (17) on the front side of the stems and secure using the two Stem Clamp Screws (19) starting from the back side – do not tighten at this time.
5. Secure the Actuator to the Valve using the four Yoke Mounting Bolts (28) using a 1/2" wrench.
6. Install the Indicator Arm (15) with the two Indicator Arm Bolts (16) using a 3/32" hex drive. Place one bolt through the hinge hole of the Indicator Arm (15) and attach to the indicator mount on the right Yoke (1) leg. Place the other bolt through the slot in the middle of the Indicator Arm (15) and attach to the center hole of the Stem Clamp (17).
7. Make sure the Stem Clamp (17, 18) is centered so that the Indicator Arm (15) is not bound, and tighten the Stem Clamp Screws(19).

Figure 1: Actuator Mounting

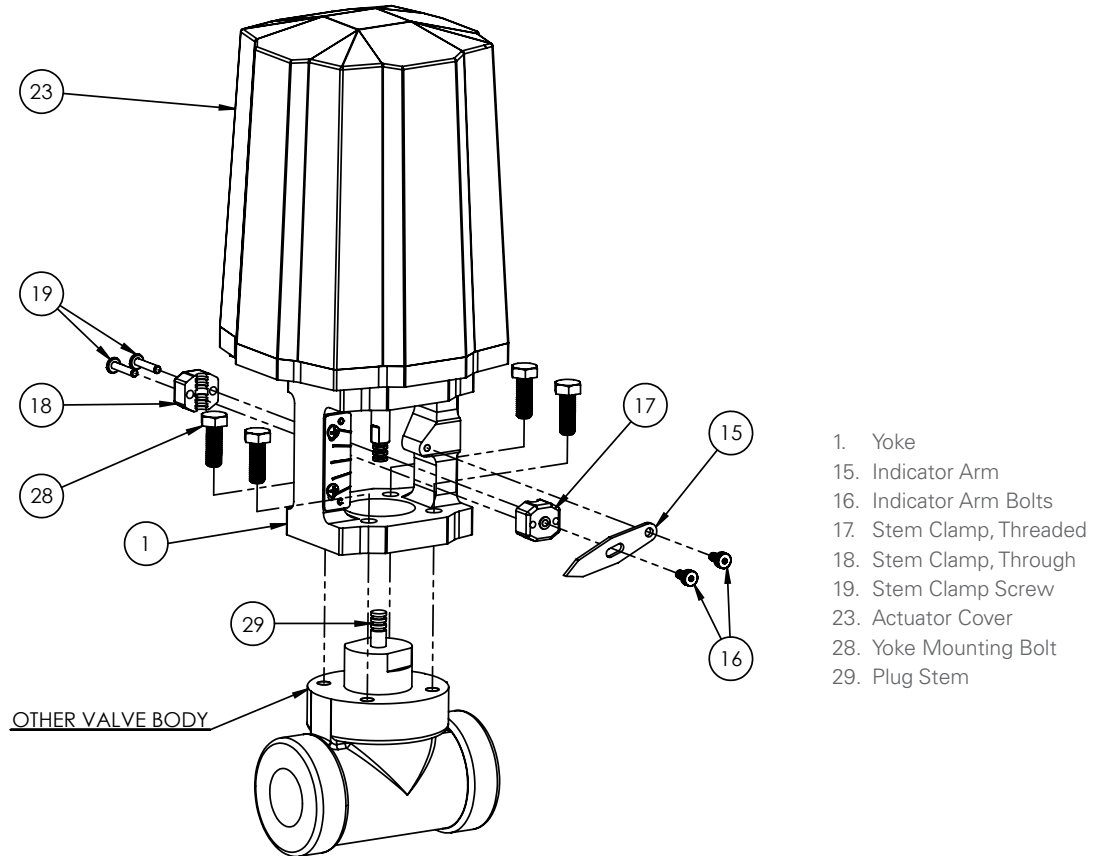

2.4 Wiring Instructions

The actuator is prewired to Terminal Block Male (25); the terminal blocks accept 30 to 14 AWG. Refer to Tables 1 and 2, and Figures 2, 3, 4 and 5 for wiring.

2.4.1 Standard Actuator Connection

1. Remove Actuator Cover (23) by unthreading the Cover Locking Bolt (20) with a ¼" hex drive and then unthreading cover from Yoke (1).
2. Disconnect Terminal Block Female (24) from Terminal Block Male (25).
3. Wire power supply into terminals 1 (——— +) and 2 (----- -) on Terminal Block Female (24).
4. Wire control signal into terminal 3 (----- +) on Terminal Block Female (24) for applications using the Profire BMS – PF2100. For applications using a separate power source and/or signal, the Power Neg (-) and Signal Neg (-) should be tied together at the power source. For example, the Profire PC180 CMS system is wired to the VM80 this way. See Figure 4.

2.4.2 Wiring Diagrams

Table 1: Recommended Wire Gauge for all Wiring

CABLE LENGTH: FEET METERS	MINIMUM AWG
≤10 ft (3.0m)	20
≤25 ft (7.6 m)	18
≤50 ft (15.2 m)	16
>50 ft (15.2 m)	14

Table 2: Terminal Descriptions

#	LINE	WIRE	DESCRIPTION
1	——	VDC Pos (+)	Power Supply to Actuator (12 VDC to 24 VDC)
2	-----	VDC Neg (-)	
3	-----	Signal Pos (+)	Control Signal Input (4–20 mA or 0-5 V) to Actuator

Figure 2: Wiring Diagram

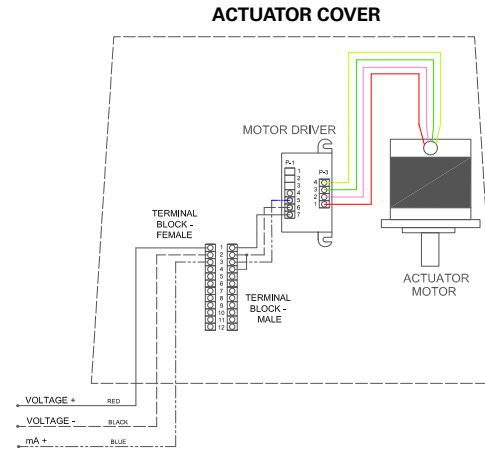

Figure 3: Terminal Wiring Diagram

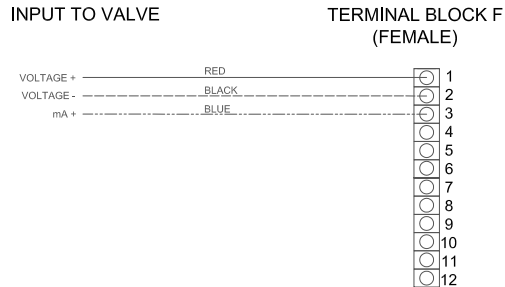

Figure 4: PF2100 BMS Wiring Diagram

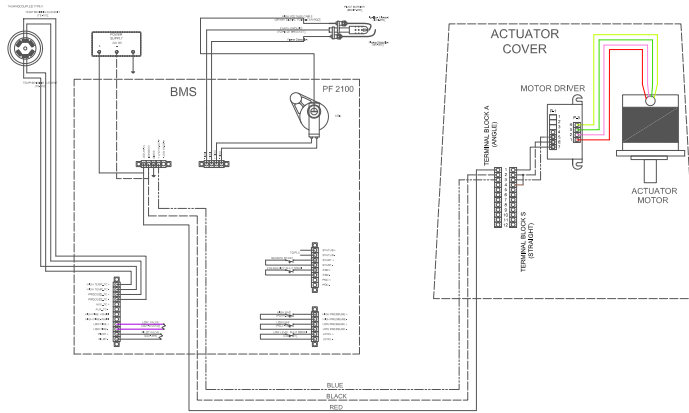
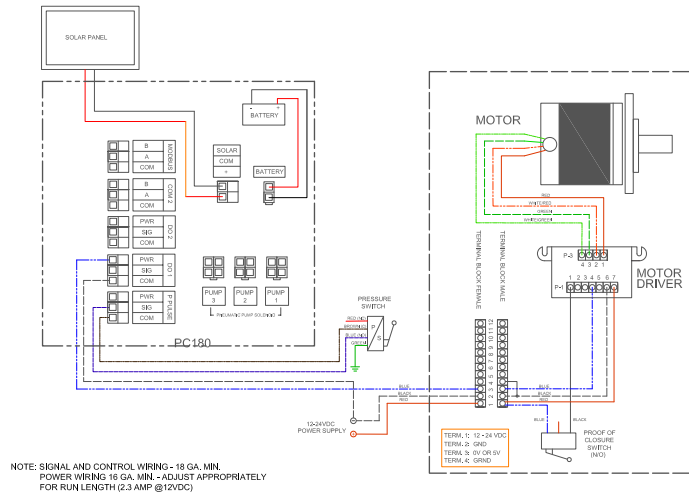

Figure 5: PC180 Wiring Diagram



NOTE: Figures 4 and 5 are for reference only; please refer to the corresponding Profire manual for detailed instructions.

2.5 Start-Up

Refer to Figures 2, 4 and 5 while following these instructions.

1. Reconnect Terminal Block Female (24), Terminal Block Male (25), and tighten screws to secure the connection.
2. Replace the Actuator Cover (23), threading it on until it seats on the Yoke (1). Once the cover is seated, rotate back just enough to align the features, and secure by threading in the Cover Locking Bolt (20).
3. Apply power to the power supply.
NOTE: The motor should activate at this time and drive the valve to the zero position.
4. Adjust the Stroke Indicator Plate (13) so that the Indicator Arm (15) points to the closed position and tighten the Indicator Plate Screws (14).
5. Cycle the actuator open and closed to verify that it has been installed properly.
CAUTION: Do not place fingers inside yoke opening during cycling as personal injury may occur.

3 Troubleshooting

3.1 Troubleshooting Guide

ISSUE	POSSIBLE CAUSE	RECOMMENDED ACTION
Actuator is not responding.	Wiring incorrect.	Check wiring and verify proper connections.
	No signal.	Verify signal at source.
	Driver has failed.	Replace driver.
Actuator moves erratically and does not position properly.	Motor binding due to high friction.	Verify alignment of shafts.
	Signal is not conditioned properly.	Install an isolated signal conditioner.
	Motor is damaged.	Check motor for signs of physical damage; replace if needed.
Actuator fails to close.	Position in driver is not set properly.	Cycle power off and on, motor will close and reset to zero position in driver.
	There is an obstruction in the valve.	Remove the valve from the line to verify that it seats properly.

4 Maintenance

NOTE: Failure to perform maintenance properly may void warranty and reduce suitability for use in the intended application. Profire approved parts should be used and maintenance should only be performed by qualified individuals.

Figure 6: VM80 Actuator Cutaway

1. Yoke
2. Actuator Stem Guide
3. Stem Seal X-Ring (2)
4. Actuator Stem
5. Actuator Guide Coupling
6. Motor Drive Screw
7. Driver Mounting Plate
8. Motor
9. Motor Guide Mount (2)
10. Motor Mounting Screw (4)
11. Driver
12. Driver Mounting Screw (2)
13. Stroke Indicator Plate
14. Indicator Plate Screw (2)
15. Indicator Arm
16. Indicator Arm Bolt (2)
17. Stem Clamp, Threaded
18. Stem Clamp, Through
19. Stem Clamp Screw (2)
20. Cover Locking Bolt
21. Ground Screw (2)
22. Cover O-Ring
23. Actuator Cover*
24. Terminal Block Female
25. Terminal Block Male
26. Actuator ID Plate*
27. ID Plate Screw* (2)
28. Yoke Mounting Bolts* (4)

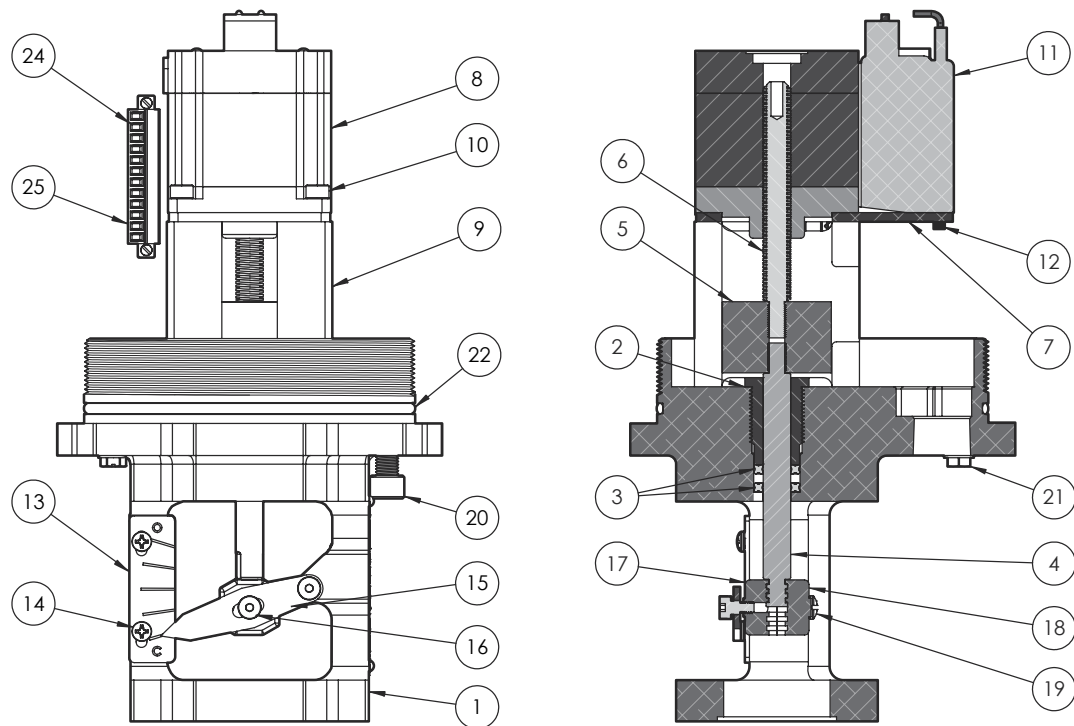

***Not indicated in Drawing**

4.1 Replacing Seals

Profire recommends the replacement of all O-rings and seals at regular intervals; approximately two years or whenever the seal is exposed due to maintenance.

It is recommended that all O-rings and seal rings are lubricated using Dow Corning MOLYKOTE® 111 compound or equivalent lubricant when replacing. Refer to Figure 6 and Figure 7.

4.1.1 Stem Seal X-Rings

Refer to Figure 6, Figure 7, and Figure 8 while following these instructions.

1. Make sure power is disconnected from the VM80 Actuator.
2. Remove Actuator Cover (23) by unthreading the Cover Locking Bolt (20) with a ¼" hex drive and then unthreading cover from Yoke (1).
3. Disconnect plug-in Terminal P1 (Figure 7) from the driver.
4. Take off the Stem Clamp (17, 18) by removing the two Stem Clamp Screws (19).
5. Remove the four Motor Mounting Screws (10) and lift the VM80 Drive Assembly straight out of the Yoke (1).
6. Turn the Actuator Stem Guide (2) out using a 7/8" socket wrench.
7. Remove the two Stem Seal X-Rings (3).
8. Lubricate the two new Stem Seal X-Rings (3) and install by pressing them into the actuator stem bore in the base of the Yoke (1). Use finger or a blunt tool to make sure they are squarely in place.
9. Clean threaded surface removing any lubricant from threads.
10. Apply a small amount of Loctite 243 or equivalent thread locker to the upper portion (near the hex flats) of the Actuator Stem Guide (2) and thread into the actuator stem bore of the Yoke (1) using a 7/8" wrench until snug.
11. Carefully insert the VM80 Drive Assembly into the Yoke (1) making sure the beveled edges of the Motor Guide Mounts (9) are to the front.
12. The Actuator Stem (4) should slide through the two new seals with a little pressure. Do not use excessive force.
13. Align the four Motor Mounting Screws (10) and secure using a 5/32" hex drive.
14. Replace the Stem Clamp (17, 18) and secure with the two Stem Clamp Screws (19) making sure that the Indicator Arm (15) is not bound.
15. Replace the plug-in Terminal P1 (Figure 7) in the Driver.

Figure 7: VM80 Drive Assembly

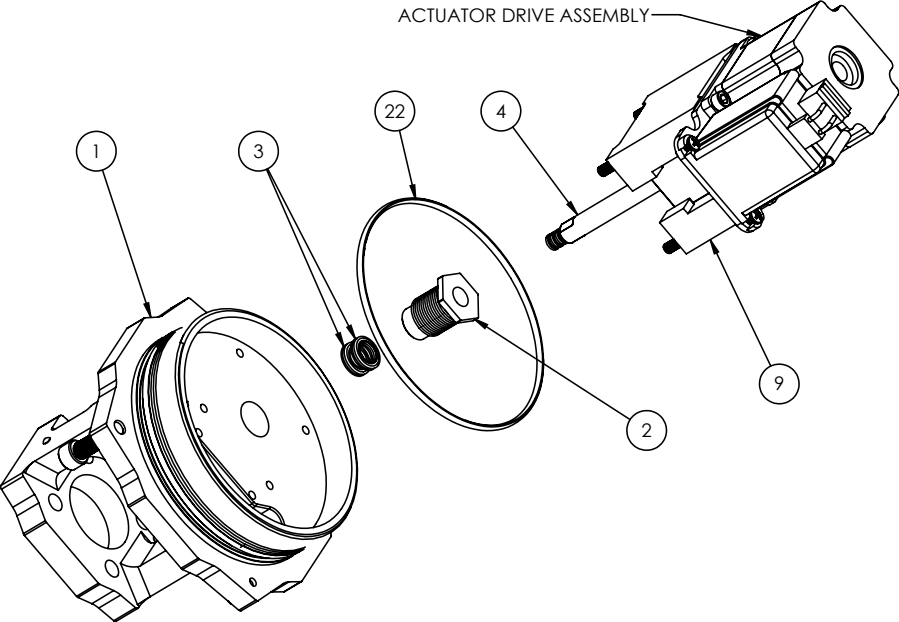

4.1.2 Cover O-Ring

- 1. Be sure to inspect the Cover O-Ring (22) for damage (e.g.stretching) any time the Actuator Cover (23) is removed.
- 2. Lubricate and, if necessary, replace the Cover O-Ring (22).

4.2 Driver Replacement

NOTE1: Driver (11) should only be replaced with a Profire approved part or warranty may be voided.

NOTE2: Driver (11) should only be replaced when the area is known to be non-hazardous as electrical connections will be exposed.

NOTE3: Make sure power is turned off while making any wiring connections. Hot plugging the connections will damage the Driver (11) and void the warranty.

1. Make sure power is disconnected from the VM80 Actuator.
2. Remove Actuator Cover (23) by unthreading the Cover Locking Bolt (20) with a ¼" hex drive and then unthreading cover from Yoke (1).
3. Disconnect plug-in Terminal P1 and the 4-pin Motor wire connector from Terminal P3 on the Driver (11).
4. Remove the two Driver Mounting Screws (12).
5. Install the new Driver (11) using the two Driver Mounting Screws (12).
6. Reconnect Terminals P1 and P3.

Figure 8: Driver Terminal Connections

PIN #	SIGNAL / PURPOSE
1	General Purpose I/O 1
2	General Purpose I/O 2
3	General Purpose I/O 3
4	General Purpose I/O 4
5	Analog Input
6	Power Ground
7	Motor Power Supply

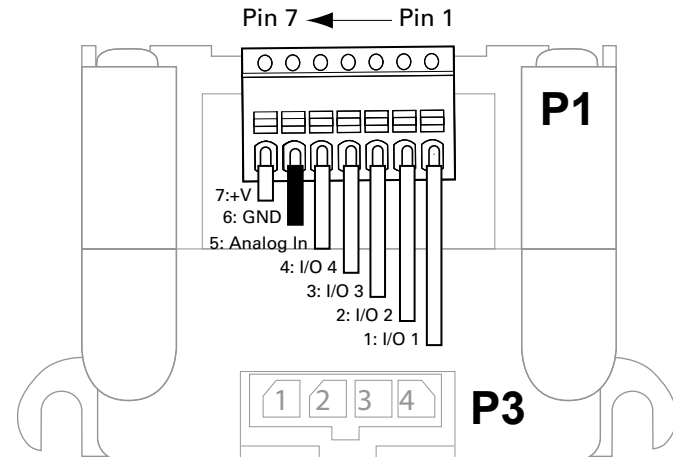

4.3 Indicator Arm Replacement

The Indicator Arm (15) is designed to break away in the event of a blockage to movement. It will not affect valve performance. Replacement is accomplished by removing the two Indicator Arm Bolts (16) using a 3/32" hex drive and installing the new Indicator Arm using the two Indicator Arm Bolts.

Figure 9: Stem Clamp and Indicator Arm Assembly

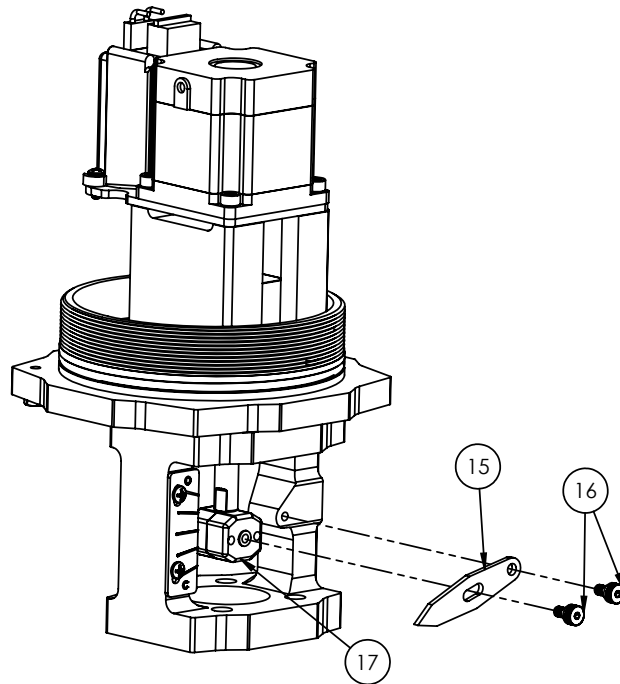

5 Ordering Information

5.1 Service Locations

CANADA– Alberta

Box 3313
Bay 12, 55 Alberta Ave
Spruce Grove, AB T7X 3A6

USA–Utah

321 S 1250 W
Suite 1
Lindon, UT 84042

USA–Texas

19407 Park Row
Suite 100
Houston, TX 77084

USA–Texas

305 Sam Houston Dr.
Unit E
Victoria, TX 77901

USA–Oklahoma

4334 NW Expressway
Suite 281
Oklahoma City, OK 73116

USA–Pennsylvania

18815 Route 287
Tioga, PA 16495

Toll Free: 855.776.3473 | www.profireenergy.com

Profire Energy, Inc., and other Profire Energy, Inc. entities, make no warranty or guarantee, express or otherwise, regarding any Profire product. Profire Energy, Inc. took reasonable efforts to ensure the product is designed and manufactured to operate as intended. Profire Energy, Inc., and any Profire Energy, Inc. entities, take no responsibility for the selection, use, or maintenance of any product. The end user/purchaser assumes all responsibility for selection, use, and maintenance of the Profire product. Nothing contained in this brochure should be construed as making a warranty or guarantee, express or otherwise, regarding any Profire product. While Profire Energy, Inc. provides general information within this brochure, it cannot provide specific data or warning for all possible applications. The end user/purchaser assumes responsibility for the selection, use, and maintenance of the Profire product in their desired location. All sales of any Profire product are subject to Profire Energy, Inc.'s terms and conditions. The terms and conditions are available upon request.

Profire VM80 and the Profire Energy, Inc. logo within this brochure are marks owned by Profire Energy, Inc. All other marks are the property of their respective owners. (See Profire's TM policy online)

The end user/purchaser must be responsible for reading and understanding the information contained within this brochure. While the information provided herein is believed to be accurate, the information should not be considered certified and there is no guarantee of final results when relying on the information found herein. Profire Energy, Inc. works hard to maintain industry-leading products. Therefore, the products are subject to change without notice. Changes to Profire products, and information on all Profire products, can be found at profireenergy.com. Should concerns regarding these provisions arise, the end user/purchaser can contact Profire Energy, Inc. All contact information can be found at profireenergy.com.



www.profireenergy.com

© 2015 PROFIRE